

EXPEDITION

XP40i
XP40iw

PORTABLE PA SYSTEMS



Owner's Manual

SAMSON[®]

WARNING

TO PREVENT FIRE OR SHOCK HAZARD. DO NOT USE THIS PLUG WITH AN EXTENSION CORD, RECEPTACLE OR OTHER OUTLET UNLESS THE BLADES CAN BE FULLY INSERTED TO PREVENT BLADE EXPOSURE. TO PREVENT FIRE OR SHOCK HAZARD. DO NOT EXPOSE THIS APPLIANCE TO RAIN OR MOISTURE. TO PREVENT ELECTRICAL SHOCK, MATCH WIDE BLADE PLUG TO WIDE SLOT AND FULLY INSERT.



This lightning flash with arrowhead symbol, within an equilateral triangle, is intended to alert the user to the presence of uninsulated “dangerous voltage” within the product’s enclosure that may be of sufficient magnitude to constitute a risk of electric shock to persons.

CAUTION

**RISK OF ELECTRIC SHOCK
DO NOT OPEN**

Warning: To reduce the risk of electric shock, do not remove cover (or back). No user-serviceable parts inside. For service, refer to qualified service personnel.



The exclamation point within an equilateral triangle is intended to alert the user to the presence of important operating and maintenance (servicing) instructions in the literature accompanying the appliance.

IMPORTANT SAFETY INSTRUCTIONS

1. Read these instructions.
 2. Keep these instructions.
 3. Heed all warnings.
 4. Follow all instructions.
 5. Do not use this apparatus near water.
 6. Clean only with dry cloth.
 7. Do not block any ventilation openings. Install in accordance with the manufacturer’s instructions.
 8. Do not install near any heat sources such as radiators, heat registers, stoves, or other apparatus (including amplifiers) that produce heat.
 9. Do not defeat the safety purpose of the polarized or grounding type plug. A polarized plug has two blades with one wider than the other. A grounding type plug has two blades and a third grounding prong. The wide blade or the third prong are provided for your safety. If the provided plug does not fit into your outlet, consult an electrician for replacement of the obsolete outlet.
 10. Protect the power cord from being walked on or pinched particularly at the plugs, convenience receptacles, and at the point where they exit from the apparatus.
 11. Only use attachments/accessories specified by the manufacturer.
 12. Use only with the cart, stand, tripod, bracket, or table specified by the manufacturer, or sold with the apparatus. When a cart is used, use caution when moving the cart/apparatus combination to avoid injury from tip-over.
- 
13. Unplug the apparatus during lightening, sort or when unused for long periods of time. Refer all servicing to qualified personnel. Service is required when the apparatus has been damaged in any way, such as power supply cord or plug is damaged, liquid has been spilled or objects have fallen into the apparatus has been exposed to rain or moisture, does not operate normally, or has been dropped.
 14. This appliance shall not be exposed to dripping or splashing water and that no object filled with liquid such as vases shall be placed on the apparatus.
 15. Caution-to prevent electrical shock, match wide blade plug wide slot fully insert.
 16. Please keep a good ventilation environment around the entire unit.

ATTENTION: Pour éviter tout risque d'électrocution ou d'incendie, ne pas exposer cet appareil à la pluie ou à l'humidité. Pour éviter tout risque d'électrocution, ne pas ôter le couvercle ou le dos du boîtier. Cet appareil ne contient aucune pièce remplaçable par l'utilisateur. Confiez toutes les réparations à un personnel qualifié. Le signe avec un éclair dans un triangle prévient l'utilisateur de la présence d'une tension dangereuse et non isolée dans l'appareil. Cette tension constitue un risque d'électrocution. Le signe avec un point d'exclamation dans un triangle prévient l'utilisateur d'instructions importantes relatives à l'utilisation et à la maintenance du produit.

Consignes de sécurité importantes

1. Veuillez lire toutes les instructions avant d'utiliser l'appareil.
2. Conserver ces instructions pour toute lecture ultérieure.
3. Lisez avec attention toutes les consignes de sécurité.
4. Suivez les instructions du fabricant.
5. Ne pas utiliser cet appareil près d'une source liquide ou dans un lieu humide.
6. Nettoyez l'appareil uniquement avec un tissu humide.
7. Veillez à ne pas obstruer les fentes prévues pour la ventilation de l'appareil. Installez l'appareil selon les instructions du fabricant.
8. Ne pas installer près d'une source de chaleur (radiateurs, etc.) ou de tout équipement susceptible de générer de la chaleur (amplificateurs de puissance par exemple).
9. Ne pas retirer la terre du cordon secteur ou de la prise murale. Les fiches canadiennes avec polarisation (avec une lame plus large) ne doivent pas être modifiées. Si votre prise murale ne correspond pas au modèle fourni, consultez votre électricien.
10. Protégez le cordon secteur contre tous les dommages possibles (pincement, tension, torsion, etc.). Veillez à ce que le cordon secteur soit libre, en particulier à sa sortie du boîtier.
11. Déconnectez l'appareil du secteur en présence d'orage ou lors de périodes d'inutilisation prolongées.
12. Consultez un service de réparation qualifié pour tout dysfonctionnement (dommage sur le cordon secteur, baisse de performances, exposition à la pluie, projection liquide dans l'appareil, introduction d'un objet dans le boîtier, etc.).

ACHTUNG: Um die Gefahr eines Brandes oder Stromschlags zu verringern, sollten Sie dieses Gerät weder Regen noch Feuchtigkeit aussetzen. Um die Gefahr eines Stromschlags zu verringern, sollten Sie weder Deckel noch Rückwand des Geräts entfernen. Im Innern befinden sich keine Teile, die vom Anwender gewartet werden können. Überlassen Sie die Wartung qualifiziertem Fachpersonal. Der Blitz mit Pfeilspitze im gleichseitigen Dreieck soll den Anwender vor nichtisolierter "gefährlicher Spannung" im Geräteinnern warnen. Diese Spannung kann so hoch sein, dass die Gefahr eines Stromschlags besteht. Das Ausrufezeichen im gleichseitigen Dreieck soll den Anwender auf wichtige Bedienungs- und Wartungsanleitungen aufmerksam machen, die im mitgelieferten Informationsmaterial näher beschrieben werden.

Wichtige Sicherheitsvorkehrungen

1. Lesen Sie alle Anleitungen, bevor Sie das Gerät in Betrieb nehmen.
2. Bewahren Sie diese Anleitungen für den späteren Gebrauch gut auf.
3. Bitte treffen Sie alle beschriebenen Sicherheitsvorkehrungen.
4. Befolgen Sie die Anleitungen des Herstellers.
5. Benutzen Sie das Gerät nicht in der Nähe von Wasser oder Feuchtigkeit.
6. Verwenden Sie zur Reinigung des Geräts nur ein feuchtes Tuch.
7. Blockieren Sie keine Belüftungsöffnungen. Nehmen Sie den Einbau des Geräts nur entsprechend den Anweisungen des Herstellers vor.
8. Bauen Sie das Gerät nicht in der Nähe von Wärmequellen wie Heizkörpern, Wärmeclappen, Öfen oder anderen Geräten (inklusive Verstärkern) ein, die Hitze erzeugen.
9. Setzen Sie die Sicherheitsfunktion des polarisierten oder geerdeten Steckers nicht außer Kraft. Ein polarisierter Stecker hat zwei flache, unterschiedlich breite Pole. Ein geerdeter Stecker hat zwei flache Pole und einen dritten Erdungsstift. Der breitere Pol oder der dritte Stift dient Ihrer Sicherheit. Wenn der vorhandene Stecker nicht in Ihre Steckdose passt, lassen Sie die veraltete Steckdose von einem Elektriker ersetzen.
10. Schützen Sie das Netzkabel dahingehend, dass niemand darüber laufen und es nicht geknickt werden kann. Achten Sie hierbei besonders auf Netzstecker, Mehrfachsteckdosen und den Kabelanschluss am Gerät.
11. Ziehen Sie den Netzstecker des Geräts bei Gewittern oder längeren Betriebspausen aus der Steckdose.
12. Überlassen Sie die Wartung qualifiziertem Fachpersonal. Eine Wartung ist notwendig, wenn das Gerät auf irgendeine Weise, beispielsweise am Kabel oder Netzstecker beschädigt wurde, oder wenn Flüssigkeiten oder Objekte in das Gerät gelangt sind, es Regen oder Feuchtigkeit ausgesetzt war, nicht mehr wie gewohnt betrieben werden kann oder fallen gelassen wurde.

PRECAUCION: Para reducir el riesgo de incendios o descargas, no permita que este aparato quede expuesto a la lluvia o la humedad. Para reducir el riesgo de descarga eléctrica, nunca quite la tapa ni el chasis. Dentro del aparato no hay piezas susceptibles de ser reparadas por el usuario. Dirija cualquier reparación al servicio técnico oficial. El símbolo del relámpago dentro del triángulo equilátero pretende advertir al usuario de la presencia de "voltajes peligrosos" no aislados dentro de la carcasa del producto, que pueden ser de la magnitud suficiente como para constituir un riesgo de descarga eléctrica a las personas. El símbolo de exclamación dentro del triángulo equilátero quiere advertirle de la existencia de importantes instrucciones de manejo y mantenimiento (reparaciones) en los documentos que se adjuntan con este aparato.

Instrucciones importantes de seguridad

1. Lea todo este manual de instrucciones antes de comenzar a usar la unidad.
2. Conserve estas instrucciones para cualquier consulta en el futuro.
3. Cumpla con todo lo indicado en las precauciones de seguridad.
4. Observe y siga todas las instrucciones del fabricante.
5. Nunca utilice este aparato cerca del agua o en lugares húmedos.
6. Limpie este aparato solo con un trapo suave y ligeramente humedecido.
7. No bloquee ninguna de las aberturas de ventilación. Instale este aparato de acuerdo a las instrucciones del fabricante.
8. No instale este aparato cerca de fuentes de calor como radiadores, calentadores, hornos u otros aparatos (incluyendo amplificadores) que produzcan calor.
9. No anule el sistema de seguridad del enchufe de tipo polarizado o con toma de tierra. Un enchufe polarizado tiene dos bornes, uno más ancho que el otro. Uno con toma de tierra tiene dos bornes normales y un tercero para la conexión a tierra. El borne ancho o el tercero se incluyen como medida de seguridad. Cuando el enchufe no encaje en su salida de corriente, llame a un electricista para que le cambie su salida anticuada.
10. Evite que el cable de corriente quede en una posición en la que pueda ser pisado o aplastado, especialmente en los enchufes, receptáculos y en el punto en el que salen de la unidad.
11. Desconecte de la corriente este aparato durante las tormentas eléctricas o cuando no lo vaya a usar durante un periodo de tiempo largo.
12. Dirija cualquier posible reparación solo al servicio técnico oficial. Deberá hacer que su aparato sea reparado cuando esté dañado de alguna forma, como si el cable de corriente o el enchufe están dañados, o si se han derramado líquidos o se ha introducido algún objeto dentro de la unidad, si esta ha quedado expuesta a la lluvia o la humedad, si no funciona normalmente o si ha caído al suelo.

ATTENZIONE: per ridurre il rischio di incendio o di scariche elettriche, non esponete questo apparecchio a pioggia o umidità. Per ridurre il pericolo di scariche elettriche evitate di rimuoverne il coperchio o il pannello posteriore. Non esistono all'interno dell'apparecchio parti la cui regolazione è a cura dell'utente. Per eventuale assistenza, fate riferimento esclusivamente a personale qualificato. Il fulmine con la punta a freccia all'interno di un triangolo equilatero avvisa l'utente della presenza di "tensioni pericolose" non isolate all'interno dell'apparecchio, tali da costituire un possibile rischio di scariche elettriche dannose per le persone. Il punto esclamativo all'interno di un triangolo equilatero avvisa l'utente della presenza di importanti istruzioni di manutenzione (assistenza) nella documentazione che accompagna il prodotto.

Importanti Istruzioni di Sicurezza

1. Prima di usare l'apparecchio, vi preghiamo di leggerne per intero le istruzioni.
2. Conservate tali istruzioni per una eventuale consultazione futura.
3. Vi preghiamo di rispettare tutte le istruzioni di sicurezza.
4. Seguite tutte le istruzioni del costruttore.
5. Non usate questo apparecchio vicino ad acqua o umidità.
6. Pulite l'apparecchio esclusivamente con un panno asciutto.
7. Evitate di ostruire una qualsiasi delle aperture di ventilazione. Posizionatelo seguendo le istruzioni del costruttore.
8. Non posizionatelo vicino a sorgenti di calore come radiatori, scambiatori di calore, forni o altri apparecchi (amplificatori compresi) in grado di generare calore.
9. Non disattivate la protezione di sicurezza costituita dalla spina polarizzata o dotata di collegamento a terra. Una spina polarizzata è dotata di due spinotti, uno più piccolo ed uno più grande. Una spina dotata di collegamento a terra è dotata di due spinotti più un terzo spinotto di collegamento a terra. Questo terzo spinotto, eventualmente anche più grande, viene fornito per la vostra sicurezza. Se la spina fornita in dotazione non si adatta alla vostra presa, consultate un elettricista per la sostituzione della presa obsoleta.
10. Proteggete il cavo di alimentazione in modo che non sia possibile camminarci sopra né piegarlo, con particolare attenzione alle prese, ai punti di collegamento e al punto in cui esce dall'apparecchio.
11. Staccate l'apparecchio dalla alimentazione in caso di temporali o tempeste o se non lo usate per un lungo periodo.
12. Per l'assistenza, fate riferimento esclusivamente a personale qualificato. È necessaria l'assistenza se l'apparecchio ha subito un qualsiasi tipo di danno, come danni al cavo o alla spina di alimentazione, nel caso in cui sia stato versato del liquido o siano caduti oggetti al suo interno, sia stato esposto a pioggia o umidità, non funzioni correttamente o sia stato fatto cadere.

THIS DEVICE COMPLIES WITH PART 15 OF THE FCC RULES CLASS B. OPERATION IS SUBJECT TO THE FOLLOWING TWO CONDITIONS: (1) THIS DEVICE MUST NOT CAUSE HARMFUL INTERFERENCE, AND (2) THIS DEVICE MUST ACCEPT ANY INTERFERENCE RECEIVED INCLUDING INTERFERENCE THAT MAY CAUSE UNDESIRE OPERATION. SUITABLE FOR HOME OR OFFICE USE.

Copyright 2010, Samson Technologies Corp.
Printed January, 2010 v1.
Samson Technologies Corp.
45 Gilpin Avenue
Hauppauge, New York 11788-8816
Phone: 1-800-3-SAMSON (1-800-372-6766)
Fax: 631-784-2201
www.samsontech.com

Table of Contents

Introduction	1 -2
XP40i and XP40iw Features	3
XP40i and XP40iw Front and Top Views	4
XP40i Rear View	5
XP40iw Rear View	6
XP40i and XP40iw Quick Start	7 - 8
Setting Up and Using the XP40i and XP40iw	9
Operating the XP40i and XP40iw	10 - 14
Connecting to the LINE Level Input.	10
Connecting to the Microphone Input	10
Setting a Good Level	10
Using EQ.	10
Using the Aux input.	11
Using LINK to Connect Two XP40i's	12 - 14
Using the XP40iw Wireless Microphone	15 - 18
Speaker System Specifications	19
Wireless Specifications	20

Introduction

Thank you for purchasing the Expedition XP40i all-in-one, portable sound system from Samson Technologies. The XP40i is a compact PA system ideal for use in a variety of live sound applications. The XP40i is loud and clear, producing a big sound in a surprisingly small package. The self contained PA features a 2-way speaker system employing a six-inch woofer and a 1-inch titanium tweeter, 40 watts of internal power and an onboard four-channel mixer. Plus, there's an integrated iPod dock that's compatible with the latest iPod models making the XP40i an ideal choice for music playback for any application. The mixer features two inputs for microphones, an iPod level control, as well as line inputs for connecting a laptop, CD player or even an electronic keyboard. The XP40i's mixer also provide a Bass and Treble control to adjust the overall tonal response of the sound system. A Link connector is provided so that multiple XP40i's can be configured into a larger system. Do you need a sound system for outdoor use where no electrical hook-up is available? That's no problem for the XP40i. The internal gel-cell battery allows the system to be self-powered, so you can use your sound system outside in a park, playground or ball field without the need for an electrical hook up. The XP40i's internal molded-in handle allows for easy transport and the speaker can be easily stand-mounted using the integral 1 3/8-inch speaker stand receptacle. The XP40i's cabinet is constructed using high-impact, scuff resistant, polypropylene providing excellent protection of the internal components and finished in an attractive dark charcoal color which helps keeps the unit looking good even when being transported from venue to venue. For added flexibility, the unit is also available with an onboard wireless microphone system as the model XP40iw. The XP40iw's internal VHF wireless receiver works with the included H5 wireless handheld microphone allowing a user to move freely on stage or in a crowd. The Expedition XP40i and XP40iw are ideal for business conferences, meetings, PowerPoint presentations, tradeshows, classrooms, auditoriums, playgrounds, outdoor carnivals and fairs or just about any application where high quality portable sound is needed.

Please retain the original packing materials and if possible, return the unit in the original carton and packing materials. If you purchased your Samson product outside the United States, please contact your local distributor for warranty information and service.

Introduction

This manual covers both the XP40i and XP40iw models and it should be assumed that the features are identical unless otherwise stated. In these pages, you'll find a detailed description of the features of the XP40i and XP40iw PA systems, as well as a guided tour through their control panels, step-by-step instructions for its setup and use, and full specifications. You'll also find a warranty card enclosed—please don't forget to fill it out and mail it in so that you can receive online technical support and so we can send you updated information about these and other Samson products in the future. Also, be sure to check out our website (www.samsontech.com) for complete information about our full product line.

With proper care and adequate air circulation, your Expedition system will operate trouble free for many years. We recommend you record your serial number in the space provided below for future reference.

Serial number: _____

Date of purchase: _____

Should your unit ever require servicing, a Return Authorization number (RA) must be obtained before shipping your unit to Samson. Without this number, the unit will not be accepted. Please call Samson at 1-800-3SAMSON (1-800-372-6766) for a Return Authorization number prior to shipping your unit. If you purchased your Samson product outside the United States, please contact your local distributor for warranty information and service.

XP40i and XP40iw Features

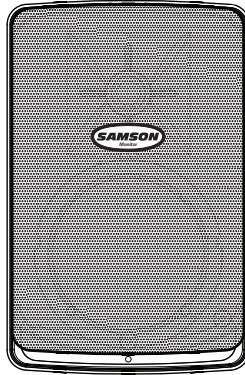

- The XP40iw and XP40i are 2-way self-powered 40-watt speaker systems.
- A deep and rich low frequency response is produced thanks to the proprietary six-inch, heavy-duty woofer.
- Built-in iPod dock for great sounding, easy playback of just about any iPod model with 30-pin standard connector.
- A one-inch titanium tweeter is fitted on a 60 x 60 degree, one-inch throat horn, for clean and clear high frequency response with even sound dispersion.
- The XP40i features a built-in rear mounted three-channel mixer and the XP40iw features a four-channel mixer, both with Mic and Line level inputs, Aux input for connecting your Computer, CD or MP3 audio device, plus Bass and Treble tone controls.
- The XP40iw features an onboard VHF wireless receiver and wireless dynamic handheld microphone transmitter provides freedom of movement for speaker or performer.
- The internal, rechargeable, Gel-cell battery provides 8 to 10 hours of operation with out the need of an electrical hook-up.
- A Link connector is supplied for expanding your sound system with additional XP40i's or XP40iw's.
- The XP40i and XP40iw are built using durable, thick-walled, solid polypropylene plastic construction and is finished in a sleek black texture.
- Three year extended warranty.

XP40i and XP40iw Front and Top Views

Front View

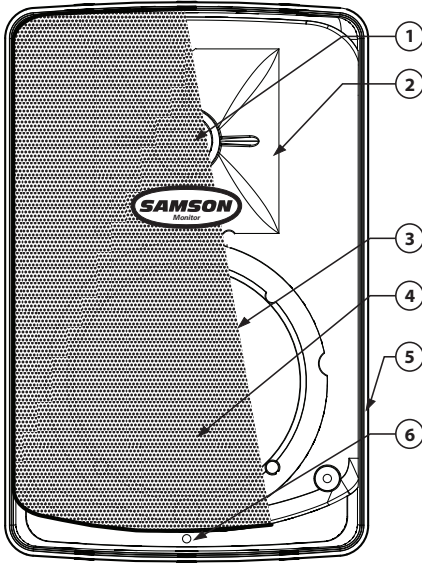

Front View

- 1 Titanium Tweeter** – A 1-inch (25mm), titanium diaphragm horn loaded tweeter produces an articulate and sweet high frequency response.
- 2 Controlled Dispersion Horn** – 1 inch throat, 60 x 60 degree wide dispersion horn provides extensive coverage and linear off- axis response.
- 3 6-Inch Woofer** – Custom designed , heavy-duty, 6" low frequency driver provides deep bass.

Top View

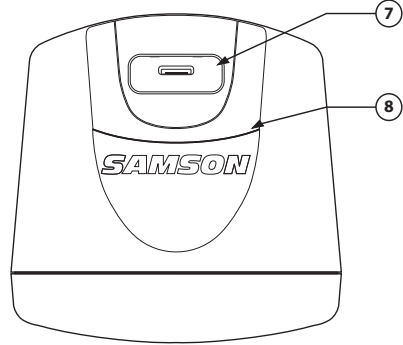

- 4 Steel Grill** – Durable steel grill provides protection for, and easy access to LF driver.
- 5 Enclosure** – Thick-wall, rugged polypropylene plastic enclosure.
- 6 POWER LED** – The Green LED illuminates when the unit is powered on.

Top View

- 7 iPod Dock** – Built-in 30-pin standard iPod dock supports most iPod models.
- 8 Handle** – Ergonomically correct molded-in carry handle provides easy transport.

XP40i Rear View

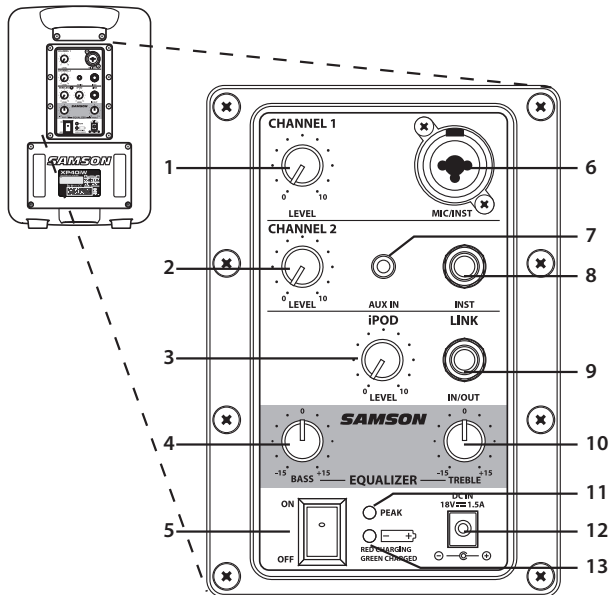

- 1 **LEVEL (CH 1)** – Used to control the level of the CHANNEL 1 input.
- 2 **LEVEL (CH 2)** – Used to control the level of the CHANNEL 2 input.
- 3 **iPod LEVEL**- Used to control the level of the iPod input.
- 4 **BASS** - Controls the low band of the Channel Equalizer, +/- 15 dB at 100Hz.
- 5 **POWER** – Switches on the XP40i's main power.
- 6 **MIC/INST (connector)** - Combo XLR plus 1/4 inch Input for connecting microphone or Instrument level signals.
- 7 **AUX IN** - 1/8-inch Auxiliary line input for connecting a Laptop, CD or MP3 player.
- 8 **INSTRUMENT Input** - 1/4-inch phone jack connector used to connect instrument or line level signals.
- 9 **LINK** - 1/4-inch phone jack connector used to link a second XP40i or XP40iw.
- 10 **Treble** - Controls the high band of the Channel Equalizer, +/- 15 dB at 10kHz.
- 11 **PEAK LED** - The Red LED illuminates at the level where distortion occurs.
- 12 **DC POWER INLET** – Connect the supplied standard DC power adapter here.
- 13 **BATTERY LED** - Show the status of the battery charge level.

XP40iw Rear View

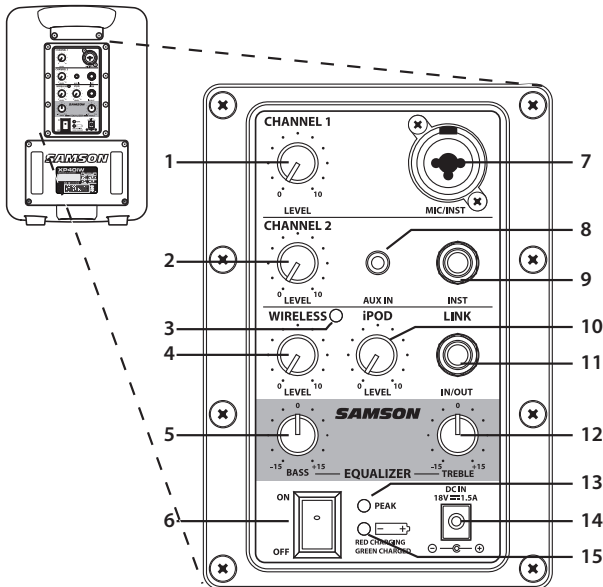

- | | |
|---|--|
| <p>1 LEVEL (CH 1) – Used to control the level of the CHANNEL 1 input.</p> <p>2 LEVEL (CH 2) – Used to control the level of the CHANNEL 2 input..</p> <p>3 RF LED - Illuminates when an RF signal is detected.</p> <p>4 LEVEL (WIRELESS) – Used to control the level of the wireless microphone.</p> <p>5 BASS - Controls the low band of the Channel Equalizer, +/- 15 dB at 100Hz.</p> <p>6 POWER – Switches on the XP40iw’s main power.</p> <p>7 MIC/INST (connector) - Combo XLR plus 1/4 inch Input for connecting microphone or Instrument level signals.</p> <p>8 AUX IN - 1/8-inch Auxiliary line input for connecting a Laptop, CD or MP3 player.</p> | <p>9 INSTRUMENT Input - 1/4-inch phone jack connector used to connect instrument or line level signals.</p> <p>10 iPod LEVEL Used to control the level of the iPod input.</p> <p>11 LINK - 1/4-inch phone jack connector used to link a second XP40i or XP40iw.</p> <p>12 Treble - Controls the high band of the Channel Equalizer, +/- 15 dB at 10kHz.</p> <p>13 PEAK LED - The Red LED illuminates at the level where distortion occurs.</p> <p>14 DC POWER INLET – Connect the supplied standard DC power adapter here.</p> <p>15 BATTERY LED - Show the status of the battery charge level.</p> |
|---|--|

XP40i and XP40iw Quick Start

In the following pages of this manual, you will find a detailed explanation of all the XP40i and XP40iw's functions and controls, but if you just want to get started quickly you can follow the steps below.

Using a Microphone

- Be sure that the XP40i's POWER switch is set to the OFF position.
- Turn the CHANNEL 1, CHANNEL 2 and iPod LEVEL controls fully counterclockwise to the off position.
- Connect the power adapter to an AC socket.
- Using a standard XLR cable, plug a microphone into the XP40i's CHANNEL 1 INPUT.
- Switch the XP40iw's Power switch to the ON position.
- While speaking into the microphone, slowly raise the CHANNEL 1 LEVEL control until you have reached the desired level.

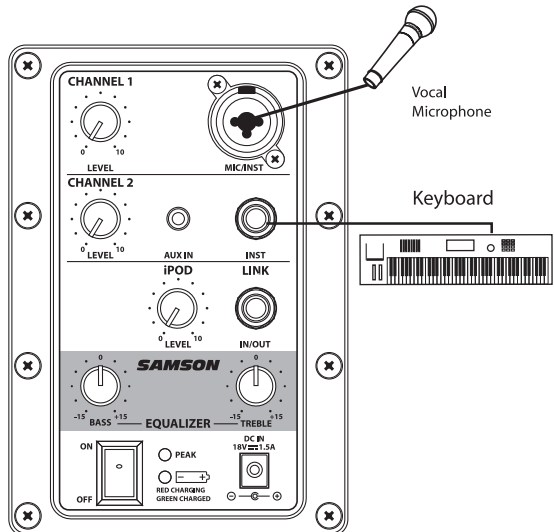

Using an Instrument Level Signal

- Be sure that the XP40i's Power switch is set to the off position.
- Turn the LINE and MIC LEVEL controls fully counterclockwise to the off position.
- Connect the power adapter to an AC socket.
- Using a standard 1/4 inch cable, connect an instrument level signal from a guitar or keyboard into the XP40i's INSTRUMENT INPUT.
- Switch the XP40i's POWER switch to the ON position.
- Now, play your keyboard or guitar while slowly raising the XP40iw's CHANNEL 2 LEVEL control until you have reached the desired level.

IMPORTANT NOTE: Be sure to keep the MIC LEVEL control all the way off if there is no microphone connected.

XP40i and XP40iw Quick Start

XP40i and XP40iw - iPod Playback

Your Expedition XP40i system has many sophisticated features, but if you just want to play music from your iPod, you can follow the simple steps below to get started.

- Unpack the XP40i or XP40iw system components and included adapter. Be sure to save the packaging in case you ever move or need to send the unit for service.
- Set the XP40i in place where you want to listen to your music.
- Turn all the input channels down by rotating the LEVEL control knobs to their fully counter clockwise position. Then, set the BASS and TREBLE controls to their 12:00 positions.
- Check that the rear panel POWER switch is set to the OFF position. Then, plug the supplied power adapter into the rear panel DC inlet, and then, plug the wall socket adapter into an acceptable power outlet, but don't turn the unit on just yet.
- If your iPod came with a dock adapter (most do) install it into the iPod dock on top of the XP40i or XP40iw.
- Next, install your iPod into the XP40i or XP40iw. Be sure the iPod is seated all the way in and that it's making a good connection in the dock.
- Now power on your XP40i system using the rear panel POWER switch but keep the volume down to start.
- Now press Play on your favorite iPod tune and adjust the XP40i's rear panel iPod LEVEL control until you reach a comfortable listening level.

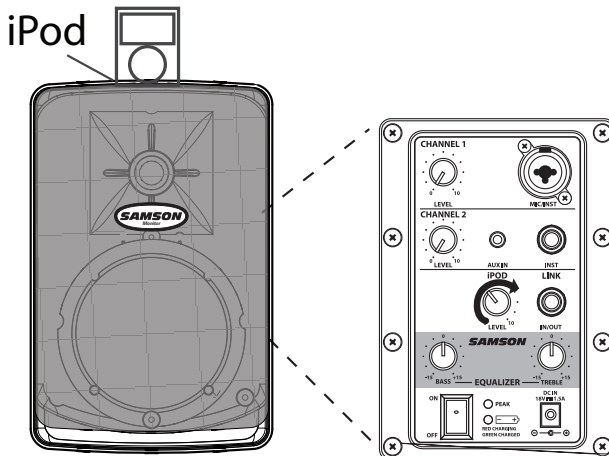

Setting Up and Using the XP40i and XP40iw

Microphone Positioning - How to Reduce Feedback

Feedback is the annoying howling and squealing that is heard when the microphone gets too close to the speaker and the volume is high. You get feedback when the microphone picks up the amplified signal from the speaker, and then amplifies through the speaker again, and then picks it up again, and so on and so on. In general, it is always recommended that any LIVE mic (a mic that's on) is positioned behind the speaker enclosures. This will give you the best level from your system before feedback. One possible exception is when you are adjusting the sounds of the microphones, since you want to listen in front of the speaker to hear properly. To do this, lower your mixers MAIN VOLUME while setting the EQ and effect from in front of the speakers. Once you have the sound you like, move the microphones to behind the speakers and raise the Main volume.

Speaker Placement

Whenever possible, it is a good idea to raise the speakers above the heads of the listening audience. The XP40i enclosures feature standard 1 3/8" pole mount receptacles, which are compatible with speaker stands from a variety of manufacturers. In a smaller setting like a school cafeteria, library, or a mall kiosk, you can also use the XP40i in one of the tilt back monitor positions, which will improve the projection of the speakers and may eliminate the need for speaker stands.

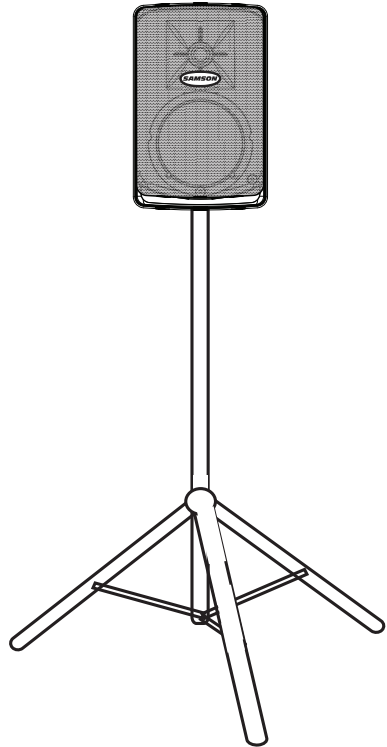

Operating the XP40i and XP40iw

Making Connections

Connecting to the LINE Level Input

Use these inputs to connect a high impedance microphone, keyboard, guitar (with a pick-up), or any other line or instrument level signals. Use a standard shielded instrument cable terminated with ¼-inch phone plug to make your connection.

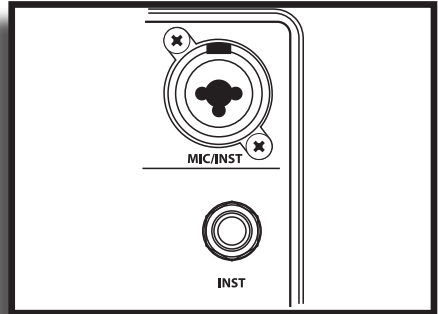

Connecting to the Microphone Input

Use these inputs to connect Low Impedance microphones. The MIC inputs have a nominal operating level of -50dBV through -20dBV. Use a standard 3-pin XLR cable to make your connection.

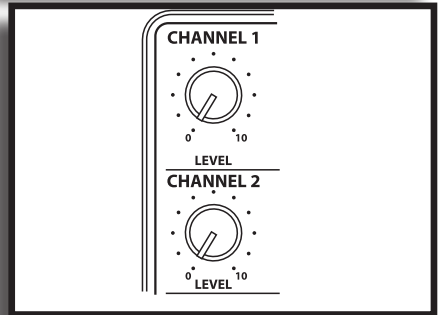

Setting a Good Level

Use the Channel LEVEL controls to set the individual volume of your microphone, instruments and iPod.

The PEAK LED illuminates when the signal sending to the internal amplifier begins to reach a level where distortion occurs. If the CLIP lights stay on, your mix is too hot and you need to lower the LEVEL controls. It is okay for the PEAK light to occasionally light, however they should go off quickly and not stay on.



Using EQ

The XP40i and XP40iw feature a 2-band equalizer allowing you to adjust the systems overall high and low frequencies. The system's frequency response is flat when the knobs are in the "12:00" position. Rotating the knob towards the right will boost the corresponding frequency band by 15dB, and rotating it towards the left will cut the frequency by 15dB.

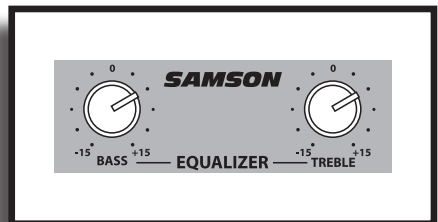

Operating the XP40i and XP40iw

Setting the EQ for Music

If you are using the XP40i or XP40iw for music playback turn up the BASS and TREBLE slightly to produce a “hi-fi” frequency response that accentuates the low and high range.

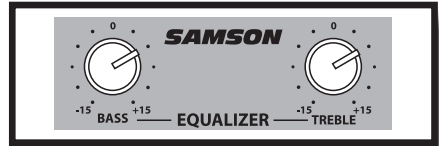

Setting the EQ for Vocal

If you are using your XP40i with a microphone for speech only you and reduce the BASS and TREBLE slightly, which will produce a frequency response that accentuates the vocal range.

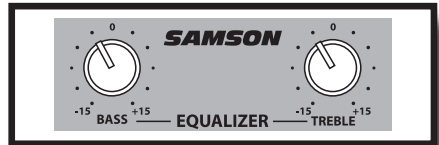

Using the Aux input

The XP40i and XP40iw provide a convenient 1/8-inch line level input, which is ideal for connecting a laptop or MP3 player. Use a standard 1/8-inch shielded cable to make the connection. Note: Although the XP40i and XP40iw are mono units you can plug a stereo signal into the AUX input and it will automatically convert the signal to mono.

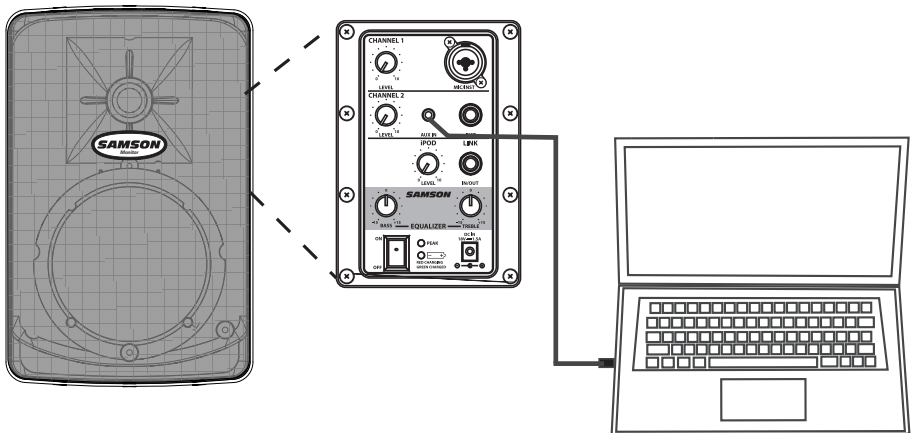

Operating the XP40i and XP40iw

Charging the XP40i and XP40iw

The XP40i and XP40iw have an internal Gel cell battery allowing you to use the sound system without a power cord for up to four hours. Your actual battery life will depend on what your application is. For example, if you use the XP40i to play back loud disco music, the battery life will be less than if you use it for light speech. To charge the XP40i or XP40iw battery follow these simple steps:

- Check that the POWER switch is set to the "OFF" position. Next, plug the supplied power adapter into the rear panel DC inlet and then into an appropriate power outlet.
- Take notice of the rear panel CHARGE LED which will illuminate red if the battery level is not fully charged.
- Leave the unit off for up to 4 hours until you see the CHARGE LED change to green indicating the XP40i or XP40iw battery is fully charged.

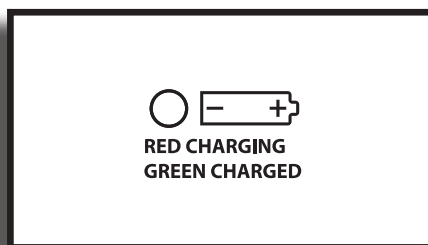

Using the LINK connection

You can expand your sound system with a second XP40i or XP40iw using the LINK connector. Use a standard shielded instrument cable terminated with two ¼-inch phone plugs and connect each end to the ¼-inch LINK jacks located on the XP40i and XP40iw's rear panels. Following are some examples of connecting multiple XP40i's and XP40iw's.

Operating the XP40i and XP40iw

Using LINK to Connect Two XP40i's

To use two XP40i's as one system is simple. Just connect each side a standard ¼-inch Shielded instrument cable to the LINK jack located on the XP40i's rear panels. Both mixers and the microphones or instruments connected to each of the individual XP40i's will be heard in both speakers.

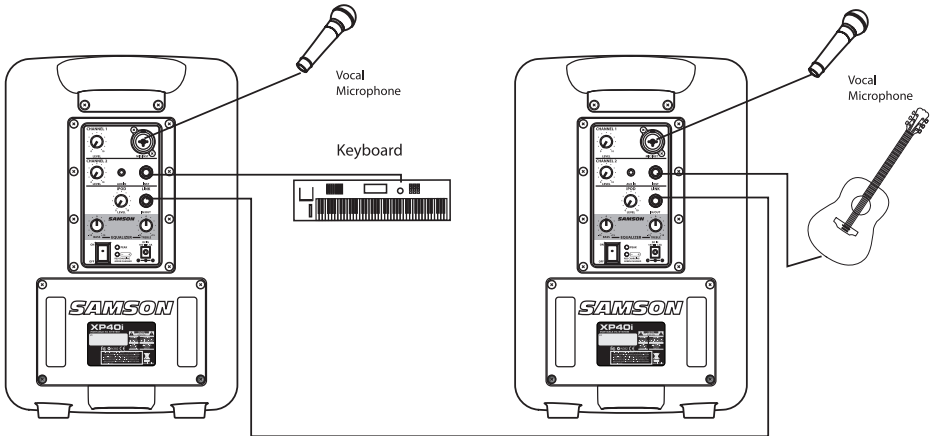

One XP40i and One XP40iw.

To use an XP40i and XP40iw as one system, just connect each side using a standard, ¼-inch, shielded instrument cable to the LINK jack located on the XP40i and XP40iw's rear panels. Both mixers and the instruments or microphones (including the wireless microphone) connected to each of the individual XP40i's will be heard in both speakers.

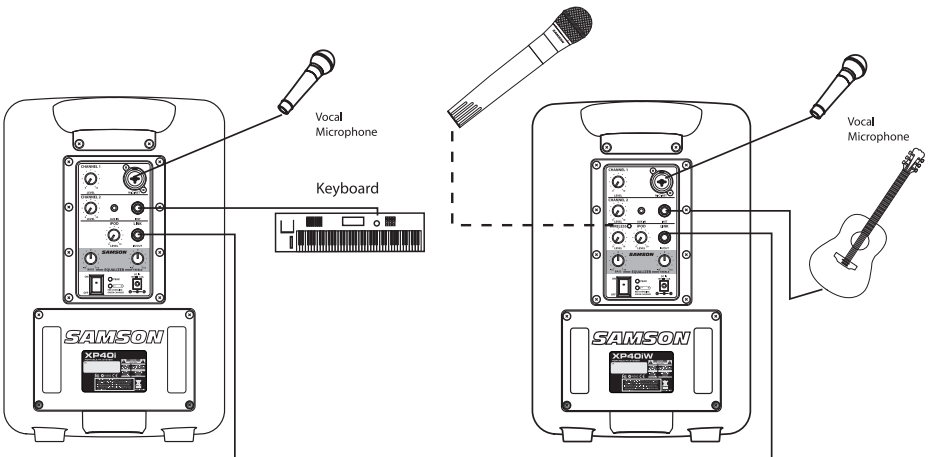

Operating the XP40i and XP40iw

Using LINK to Connect Two XP40iw's

To use two XP40iw's as one system, just connect each side using a standard, 1/4-inch, shielded instrument cable to the LINK jack located on the XP40iw's rear panels. Both mixers and the microphones (including the wireless microphone) or instruments connected to each of the individual XP40iw's will be heard in both speakers. Note: Be sure each XP40iw's wireless frequency is on a **different channel** so that the two wireless mics will work together simultaneously.

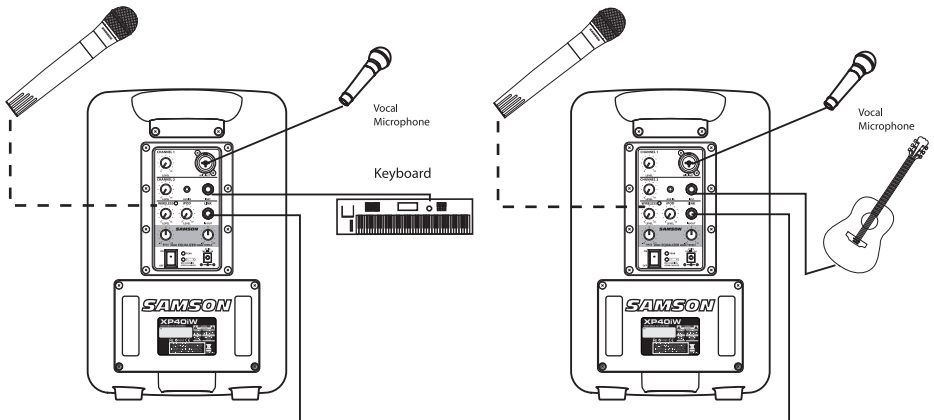

Using the XP40iw Wireless Microphone

1: Audio on-off switch-

When set to the "ON" position, audio signal is transmitted. When set to the "OFF" position, the audio signal is muted. Because the carrier signal remains during muting, no "pop" or "thud" will be heard. Note that turning this off does **not** turn off the transmitter power—it is simply a way to temporarily mute the transmission of audio signal. If you don't plan on using the HT5 for extended periods, turn off its power by using the power on-off switch (see #3 below).

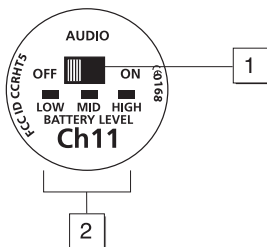

2: Battery level meter - This set of three multicolor LEDs indicates relative battery power, indicating whether the installed battery is at low (red), mid (yellow) or high (green) strength. One or more of these will light whenever the HT5 is powered on (see #3 below). When all three are lit, the battery is at maximum strength. When only the red "low" indicator lights, RF performance is degraded and the battery needs to be replaced.

3: Power on-off switch* - Use this to turn the HT5 on or off (to conserve battery power, be sure to leave it off when not in use).

4: Gain control (trimpot) - This input sensitivity control has been factory preset to provide optimum level for the particular microphone capsule provided with your XP40iw system and so we recommend that this not be adjusted manually. If necessary, however, you can use the supplied plastic screwdriver to raise or lower the input level. See the "Setting Up and Using Your XP40iw System" section on page 5 in this manual for more information.

5: Battery holder - Insert a standard 9-volt alkaline battery here, being sure to observe the plus and minus polarity markings shown. We recommend the Duracell MN 1604 type battery. Although rechargeable Ni-Cad batteries can be used, they do not supply adequate current for more than four hours. **WARNING:** Do not insert the battery backwards; doing so can cause severe damage to the HT5 and will void your warranty.

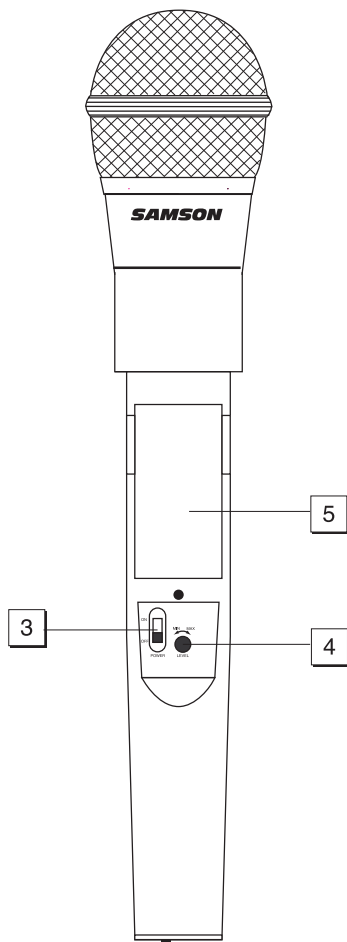

* Be sure to turn down the WIRELESS LEVEL control before turning transmitter power on or off, or an audible pop may result.

Using the XP40iw Wireless Microphone

The basic procedure for setting up and using your XP40iw Wireless System takes only a few minutes:

1. For the XP40iw system to work correctly, both the receiver and transmitter must be set to the same channel. Remove all packing materials (save them in case of need for future service) and check to make sure that the supplied receiver and transmitter are set to the same channel. If these channels do not match, contact your Samson Technical Support at 1-800-372-6766.
2. Physically place the XP40iw where it will be used (the general rule of thumb is to maintain "line of sight" between the receiver and transmitter so that the person using the microphone can see the XP40iw).
3. Make sure the Power on-off switch in your HT5 handheld transmitter is set to "Off."
4. On the HT5 handheld transmitter, unscrew the bottom section of the microphone by turning it counterclockwise and then slide it off.
5. Place a fresh 9-volt alkaline battery in the transmitter battery holder, taking care to observe the polarity markings.
6. Turn the WIRELESS LEVEL knob on the XP40iw completely counterclockwise. Connect the supplied AC adapter to the DC Input on the rear panel of the XP40iw, then plug the adapter into any standard AC outlet. Press the rear panel Power switch to turn on the XP40iw.
7. Turn on the power to the HT5 transmitter (using its Power on-off switch); all three Battery strength LEDs will light if the battery is sufficiently strong. At this point, the RF LED on the rear panel of the receiver will light. Replace the bottom section of the HT5 handheld microphone by sliding it on and then screwing it back on. Leave the transmitter off for the moment.
8. Now it's time to set the audio level. Make sure that your HT5 transmitter is unmuted by setting its Audio switch to "On." Speak or sing into the mic at a normal performance level and raise the WIRELESS LEVEL control until the desired level is reached.

Bear in mind also that the HT5 microphone is **unidirectional** which means it picks up sound from the front of the mic and rejects sound from the rear. This will help

Using the XP40iw Wireless Microphone

reduce the chance of feedback. In general, you can avoid feedback by taking care not to use any microphone directly in front of a PA speaker (if this is unavoidable, try using the equalizer to attenuate those high- or mid-range frequencies which are causing the feedback "squealing").

9. If you hear distortion at the desired volume level, check the rear panel PEAK LED. If it is lit red, turn down the WIRELESS LEVEL until it lights only occasionally. If you still hear distortion, do the following:

- The HT5 transmitter's Gain control has been factory preset to provide optimum level for the particular microphone model being used and so no adjustment should be necessary. Any distortion present should therefore simply be a matter of the microphone being too close to the mouth; try moving it further away. If this does not solve the problem, use the supplied plastic screwdriver to turn the Gain control (trimpot) on the HT5 slowly counterclockwise until the distortion disappears.

Note that following this setup procedure, you can always lower the Volume knob of the XP40iw in order to further attenuate the output signal if necessary.

10. Conversely, if you hear a weak, noisy signal at the desired volume level (and with the WIRELESS control of the XP40iw turned fully clockwise), use the supplied plastic screwdriver to turn the Gain control (trimpot) on the HT5 slowly clockwise until the signal reaches an acceptable level.

Using the XP40iw Wireless Microphone

11. When first setting up the XP40iw System in a new environment, it's always a good idea to do a walk-around in order to make sure that coverage is provided for your entire performance area. As you do so, the "RF" LED on the rear panel of the XP40iw should always remain lit. Always try to minimize the distance between transmitter and receiver as much as possible so that the strongest possible signal is received from all planned transmission points.

If you have followed all the steps above and are experiencing difficulties, contact your local distributor or, if purchased in the United States, call Samson Technical Support (1-800-372-6766) between 9 AM and 5 PM EST.

Specifications

Amplifier

Power Output	40-Watt
No. of Mic Input	1 x Wired mic / 1 x Wireless mic (XP40iw only)
LEVEL Controls	1 x Wired mic / 1 x Wireless mic (XP40iw only)
iPod	
Tone Control	1 x Treble / 1 x Bass, ± 15 dB Independent
Mic/Instrument Input.	XLR / 1/4-inch combi connector
Link Input/Output	1/4-inch TS
Aux. Input	1 x 1/8-inch TRS Stereo
iPod Input	30-pin input dock
Instrument Input.	1 x 1/4-inch

Speaker

Drivers	8" Woofer + 1" HF Driver
Built-in Battery	12V / 7.5AH, Rechargeable & Sealed
Operation	Approx. 8 - 10 hours subject to operating conditions
Battery Charging.	Approx. 3-5 hours for a Single charge
AC/DC Adapter	SMPS AC100~240V, 50~60Hz/ DC18V-1.5A
Frequency Response	75 Hz to 15kHz ± 3 dB
Construction	Polypropylene internally ribbed
Grill	Perforated Steel Grill, powder coated
Mounting	Integral 1 3/8-inch Pole Mount Receptacle
Dimensions	15"(H) x 25.5"(W) x 9.5"(D) / 375mm(H) x 245mm(W) x 240mm(D)
Weight	18.5 lbs / 8.4kg Net

Wireless Specifications

HT5 Microphone Transmitter

Transmission Mode	Frequency modulation, 80KF3E, 15 kHz peak deviation
Frequency Range	173.80 MHz to 213.20 MHz, 25 frequencies
OSC System	Crystal controlled, x12 multiplication
RF Power	20 mW (USA models), 10 mW [(2 mW ERP) European / UK models]
Operating Range	300 ft.
Frequency Stability	± 10 ppm
Approvals	Complies with ETS 300 422 and FCC Part 74
Radiating Harmonic and Spurious Emission	Below limits of applicable regulations
Antenna Type	Internal
Audio Frequency Response	40 Hz to 15 kHz ±3 dB
Pre-Emphasis	50 µSec
Noise Reduction System	NE571 based compandor
Signal To Noise Ratio	> 100 dB
Maximum Input Level	0 dBv (ST5), -20 dBv (VH3)
T.H.D.	< 1% @ 1 kHz
Current Consumption	34 mA (typical)
Battery Life (MN1604 9-volt alkaline)	6 hours (typical)
Operating Temperature	-10 to +55 degrees C
Controls	Power On/Off, Audio On/Off, Level Control (Trimpot)
LED Indicator	Battery high/medium/low
Dimensions	37 (W) x 233 (H) mm (1.46 x 9.17 in.)
Weight	200 grams • 7.1 oz.

XP40iw Receiver

Receiving System	Single conversion Superheterodyne
Frequency Range	173.80 MHz to 213.20 MHz, 25 frequencies
Band A (European / UK models)	160.10 to 177.90 MHz
Band B (European / UK models)	189.10 to 210.10 MHz
Receiving Mode	80KF3E
Sensitivity	< 3 µV for 20 dB SINAD, < 10 µV for 50 dB S/N
Selectivity	120 kHz BW, nominal @ -6 dB, ± 300 kHz (adj CH), -75 dB
Squelch Sensitivity	3 µV to 250 µV adjustable
Intermediate Frequency	10.7 MHz
Local Oscillator System	Crystal controlled
Noise Reduction System	NE571 based compandor
De-emphasis	50 µsec.
Signal To Noise Ratio	> 100 dB (IHF-A) line out, > 90 dB (IHF-A), mic out
Audio Frequency Response	40 Hz to 15 kHz ±3 dB
T.H.D.	< 1% @ 1 kHz

Specifications are subject to change without notice.

Stage Wireless Microphone Systems	
Country Code Code de Pays Laender-Kuezel	Frequency Range Bande de Fréquences Autorisée Frequenzbereich
DE, ES, IT, US	174.6 – 213.2 MHz
FR	177.0, 177.6, 183.6, 184.7 MHz
GB	173.8, 174.1, 174.5, 175.0 MHz
BE	182.1, 183.3, 184.0 MHz
NL	197.4, 197.9, 200.9 MHz
All other countries	*
* Please contact your national frequency authority for information on available legal frequencies and legal use in your area.	
	

FCC Rules and Regulations

Samson wireless systems are type accepted under FCC rules parts 90, 74 and 15.

Licensing of Samson equipment is the user's responsibility and licensability depends on the user's classification, application and frequency selected.

This device complies with RSS-210 of Industry & Science Canada.

**Operation is subject to the following two conditions:
(1) this device may not cause harmful interference and (2) this device must accept any interference received, including interference that may cause Undesired operation.**

Samson Technologies Corp.
45 Gilpin Avenue
Hauppauge, New York 11788-8816
Phone: 1-800-3-SAMSON (1-800-372-6766)
Fax: 631-784-2201
www.samsontech.com